

## Required Tools and Components

### PROVIDED BY MANUFACTURER

(per module set, **Fig. 0**)

- [1] HSS switch module
- [1] HSS magnet module
- [7] Switch and magnet module self-tapping screws (#10-32 x 2")
- [2] Self-tapping screws (#6, 1" long)
- [1] HSS switch module template
- [1] HSS magnet module template
- [1] Anti-rotational threaded stud (set screw)
- [2] 1/16" plastic spacer plates
- [1] Removal-Tamper magnet
- [1] Magnet Spacer
- [2] Removal-Tamper caps

### PROVIDED BY INSTALLER

Power drill

Drills bits: #35 (.110" or 7/64")  
#21 (.159" or 5/32")  
#3/16 (.187")

Phillips screwdriver or a Phillips bit for use in the drill/bit-driver

Rule (or any linear measuring instrument)

A center punch (& hammer) for more accurate hole locations may be used

A pilot drill bit for screws (3/32" or smaller) may be used

Additional 1/16" SPACERS (10/ BAG – MAGNASPHERE P/N SP062)

UL HIGH SECURITY LEVEL 2  
CUL HIGH SECURITY  
BP 10350



### CAUTION:

MAGNASPHERE magnet modules and anti-removal magnets are extremely powerful. Take precautions to avoid the magnetic attraction of sharp tools and to avoid injury from the pinching force between the magnet and ferrous metal or other magnets.

## Installation Plan: Face-Mounted HSS for an In-Swing Door

Figure 1a

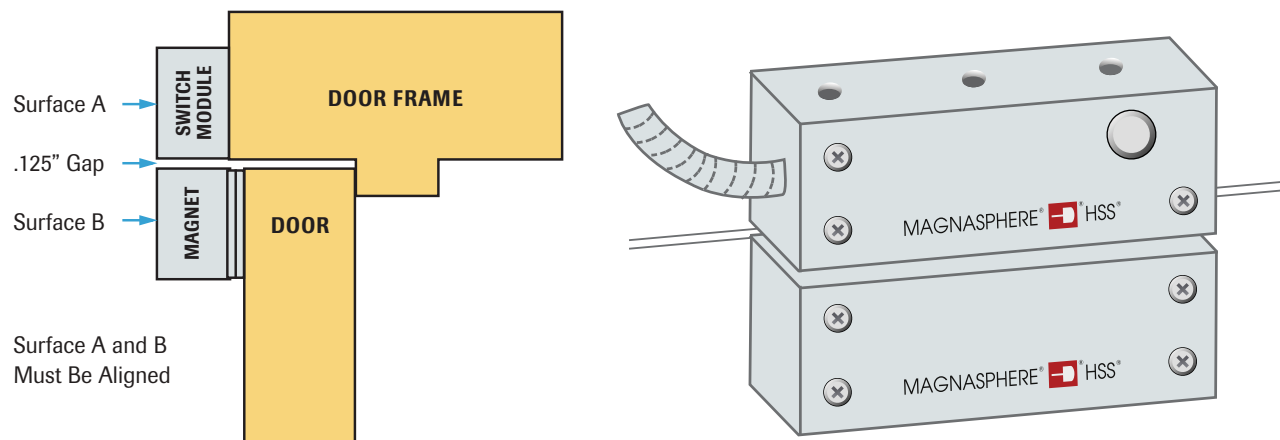

### In-Swinging Door Instructions:

#### Overview of specifications and requirements:

Ideal installation (**Fig. 1a**).

The switch module should be mounted to the door frame as close to the opening as possible without interference from the swinging door. The magnet module should be mounted directly below the switch module with every facet aligned as closely as possible; spacers may be required in order to achieve this alignment.

#### Inspecting the site for installation:

Determine the mounting site for installing the modules (the recommended placement is the top of the door, 8 inches from the latch side of door; **Fig. 2a**). The magnet module must be mounted at or within the boundaries of the door. The distance between the module surfaces, when finally mounted, must not exceed 1/8". A template guide for the

switch may be used to establish that all mounting holes for the switch will fall within the door frame area while respecting the maximum gap between modules. (**Fig. 4a**) The distance between the module surfaces when finally mounted can be up to 1/8". At the mount location on the frame, insure that there is no interference within the perimeter of the switch or for its cable.

#### Preparing the site for installation:

A clearance hole for the anti-rotational screw must be drilled into the door frame in order to mount the switch. A template for the switch has been provided for locating this hole-site. Precisely apply the template to the frame at the best-suited location. Determine if spacers are required between the switch and door in order to bring the modules into alignment.

## In-Swinging Door Instructions (cont'd.):

### Preparing the switch for installation:

For anti-tamper purposes, the switch module has two sites for an anti-rotational threaded stud; only one site will be used, depending on which installation plan is chosen. In order to install this module on the vertical face of the frame, the anti-rotational screw provided for the switch module must be threaded into the threaded hole which is opposite of the label side (back side) of the HSS switch module (**Fig. 3**). Thread the screw into the hole until 1/4" of the screw remains outside of the module. Thread exposure of 3/16" - 5/16" is acceptable.

### Installing the switch:

An optional center punch and pilot drill may be used to accurately locate and pre-drill all hole locations as marked on the template. The single clearance hole for the anti-rotational screw must now be drilled to 3/16" or 7/32" diameter at the marked location on the template. If the customer prefers, remove the template if its guidance is no longer needed.

Prepare the drill and self-tapping screws. Drill the 3 mounting hole locations which require a #10-32 screw using a #21 drill bit. Drill the Removal-Tamper screw location using the #35 drill bit for the #6 screw. Hold the switch module in position. Insure that the switch module's anti-rotational screw has been seated in its clearance hole in the frame. Drive each screw into its location until each has seated, securing the device.

### Preparing the door magnet module for installation:

**CAUTION: MAGNASPHERE's magnet module and anti-removal magnet are extremely powerful:**

**Take precautions to avoid the magnetic attraction of sharp tools and to avoid pinching fingers between the magnet and ferrous metals or other magnets.** The magnet module should be aligned directly below the switch module (**Fig 4a**). A template has been provided to assist the vertical and horizontal positioning. The plastic spacers are 1/16" thick; two can serve to achieve this spacing by filling this gap precisely. Affix the template border onto the door at 1/8" below the switch module. Temporarily position the magnet on its template area and determine if spacers are required between the magnet and door in order to bring the final vertical plane into alignment.

### Installing the door magnet module:

Prepare the drill/driver and self-tapping screws. Hold the switch module and any necessary spacers in position. Drill the 4 mounting hole locations which require a #10-32 screw using a #21 drill bit. Drive each screw in location until each has seated, securing the device.

### Finalizing installation:

Insert the Removal-Tamper magnet and then the Removal-Tamper plug into the 3/8" hole at the face of the switch module (**Fig. 4a**). NOTE: The Magnet Spacer is not used in this installation. Check that the gap between modules is less than 1/8" and that there is no interference between the switch module and swinging door. Insure that the screws are seated and that the modules are securely fastened. The mechanical installation of the modules is complete (**Fig. 5**).

## Installation Plan: Top Surface-Mounted HSS for an Out-Swing Door

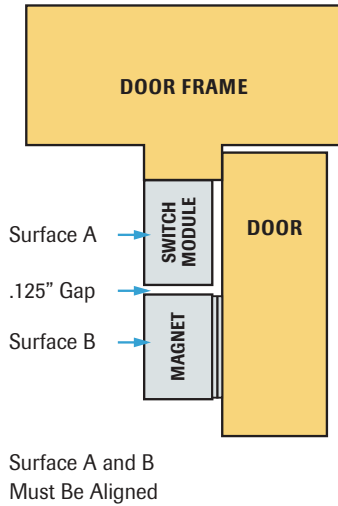
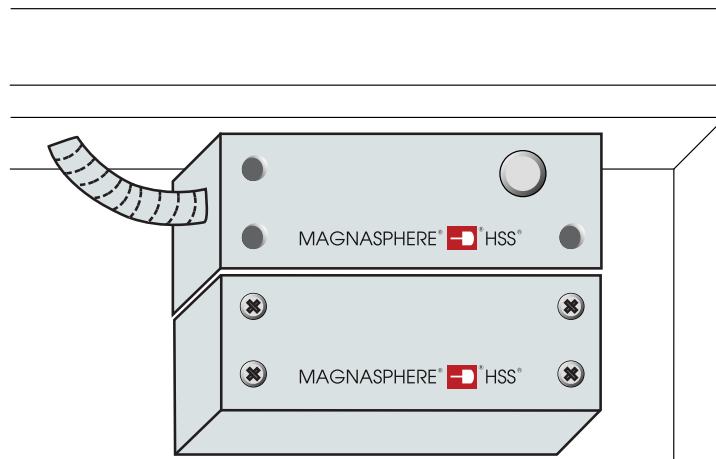

Figure 1b



### Out-Swinging Door Instructions:

#### Overview of specifications and requirements:

Ideal installation (**Fig. 1b**).

The switch module should be mounted to the door frame as close to the door opening as possible without interference from the swinging door. The magnet module should be mounted directly below the switch module with every facet aligned as closely as possible; spacers may be required in order to achieve this alignment.

#### Inspecting the site for installation:

Determine the mounting site for installing the modules (recommended placement is under the doorjamb, 8 inches from latch side of door). The magnet module must be mounted under the switch module on the door. A template guide for the switch may be used to establish that all mounting holes for the switch

will fall within the door jamb area while respecting the maximum gap between modules (**Fig. 2b**). The distance between the module surfaces when finally mounted can be up to 1/8".

#### Preparing the site for installation:

A clearance hole for the anti-rotational screw must be drilled into the door frame in order to mount the switch. A template for the switch has been provided for locating this hole-site. Precisely apply the template under the door frame to the best-suited location.

#### Preparing the switch for installation:

For anti-tamper purposes, the switch module has two sites for an anti-rotational threaded stud; only one site will be used depending on which installation plan was chosen. In order to install this module under the

## Out-Swinging Door Instructions (cont'd.)

door stop, the anti-rotational screw provided must be threaded into the threaded hole which is on the top side of the HSS switch module. **(Fig. 3)**

Thread the screw into the hole until 1/4" of the screw remains outside of the module. Thread exposure of 3/16" - 5/16" is acceptable.

### Installing the switch:

An optional center punch and pilot drill may be used to accurately locate and pre-drill all hole locations as marked on the template. The single clearance hole for the anti-rotational screw must now be drilled to 3/16" or 7/32" diameter at the marked location on the template. If the customer prefers, remove the template if its guidance is no longer needed.

Prepare the drill and self-tapping screws. Drill the 2 mounting hole locations which require #6 screws using a #35 drill bit. Hold the switch module in position. Insure that the switch module's anti-rotational screw has been seated in its clearance hole in the frame. Drive each screw into its location until each has seated, securing the device.

### Preparing the door magnet module for installation:

**CAUTION: MAGNASPHERE'S magnet module and anti-removal magnet are extremely powerful. Take precautions to avoid the magnetic attraction of sharp tools and to avoid pinching fingers between the magnet and ferrous metals or other magnets.**

The magnet module should be aligned directly below the switch module. A template has been provided to assist the vertical and horizontal positioning. The plastic spacers are 1/16" thick; two can serve to achieve this spacing by filling this gap precisely. Affix the template border onto the door at 1/8" below the switch module. Temporarily position the magnet on its template area and determine if spacers are required between the magnet and door in order to bring the final axis into alignment.

### Installing the door magnet module:

Prepare the drill/driver and self-tapping screws. Hold the switch module and any necessary spacers in position. Drill the 4 mounting hole locations which require a #10-32 screw using a #21 drill bit. Remove the magnetic safety-shunt. Drive each screw in location until each has seated, securing the device.

### Finalizing installation:

Insert the Magnet Spacer, the Removal-Tamper magnet and then the Removal-Tamper plug into the 3/8" hole at the face of the switch module (Fig. 2b). Check that the gap between modules is less than 1/8" and that there is no interference between the switch module and swinging door. Insure that the screws are seated and that the modules are securely fastened. The mechanical installation of the modules is complete **(Fig. 4b)**.

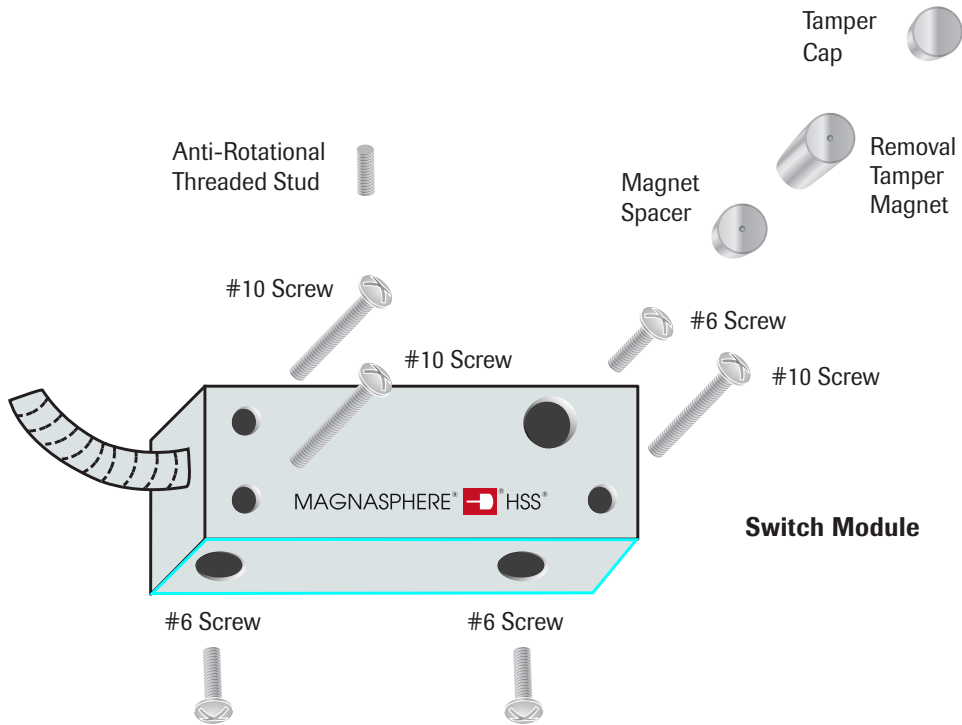

Figure 0

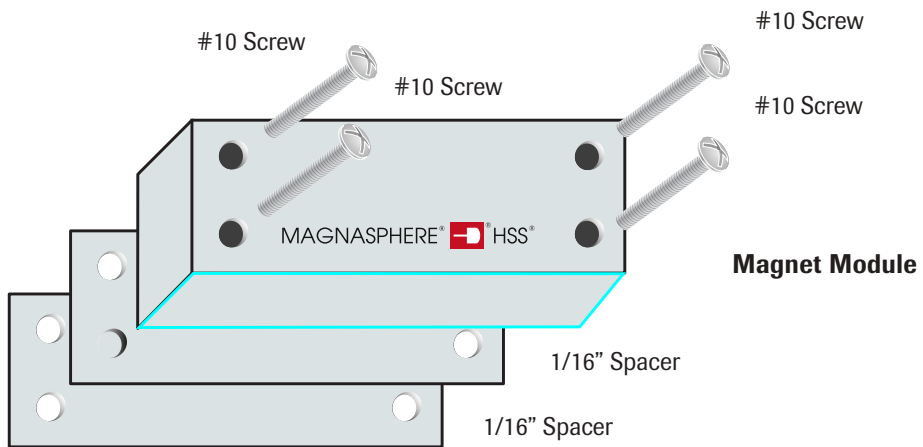

Figure 2a

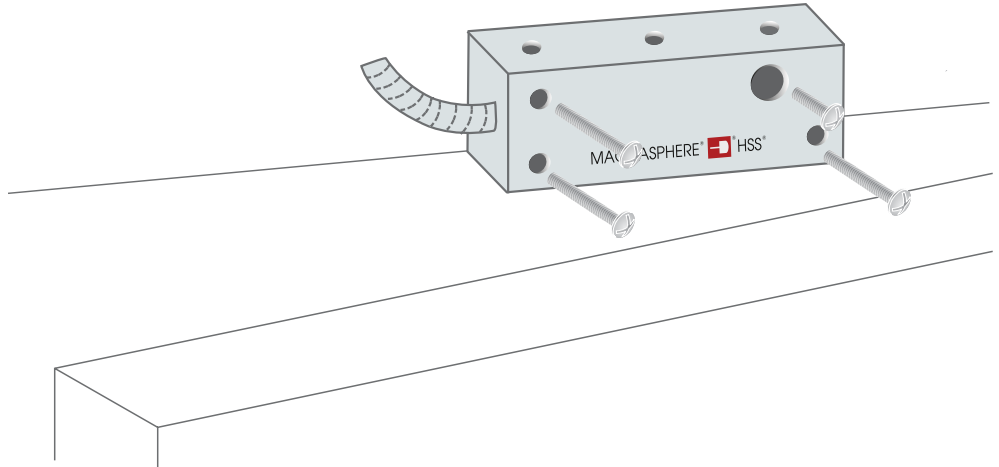

Figure 2b

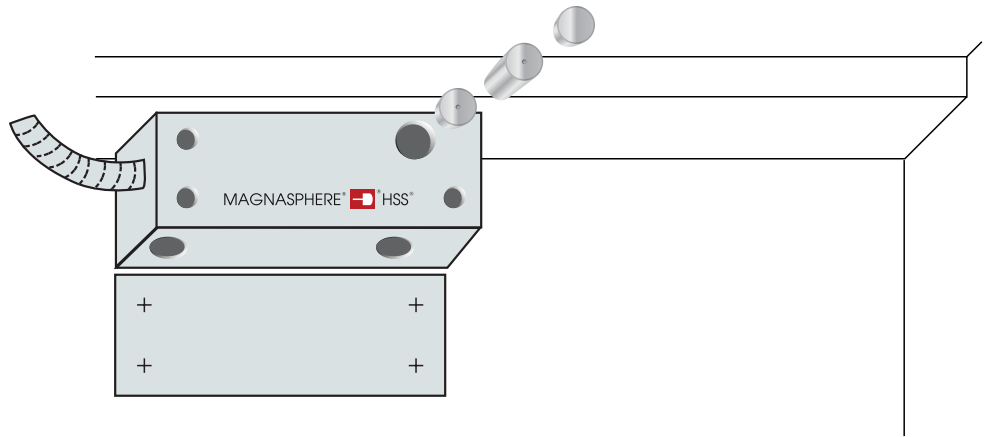

Figure 3

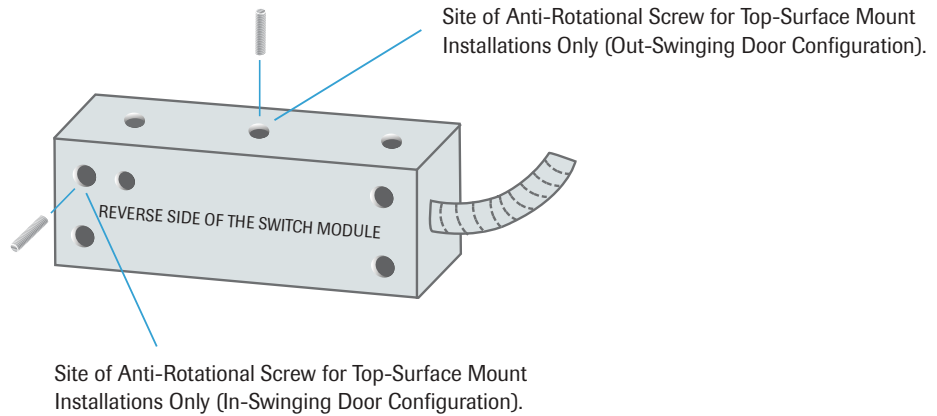

Figure 4a

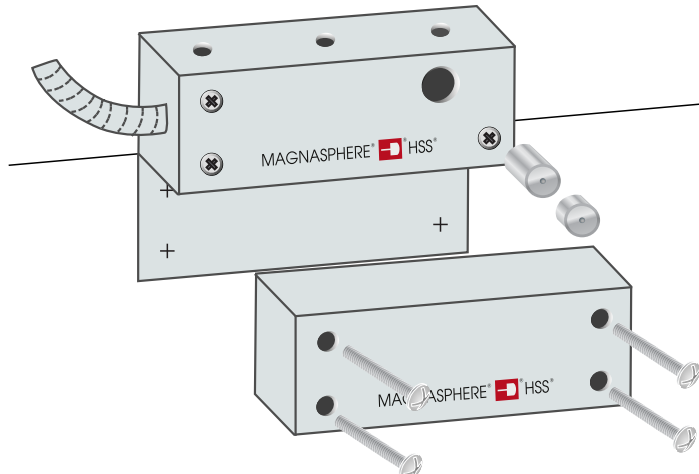

Figure 4b

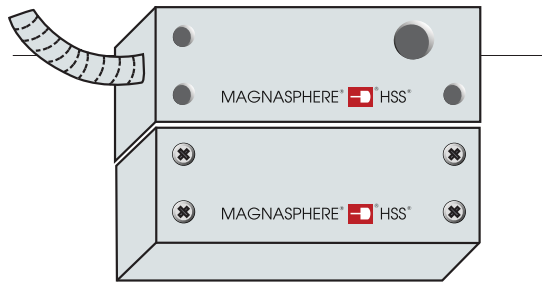
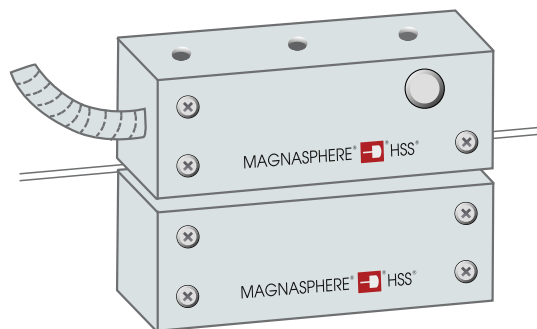
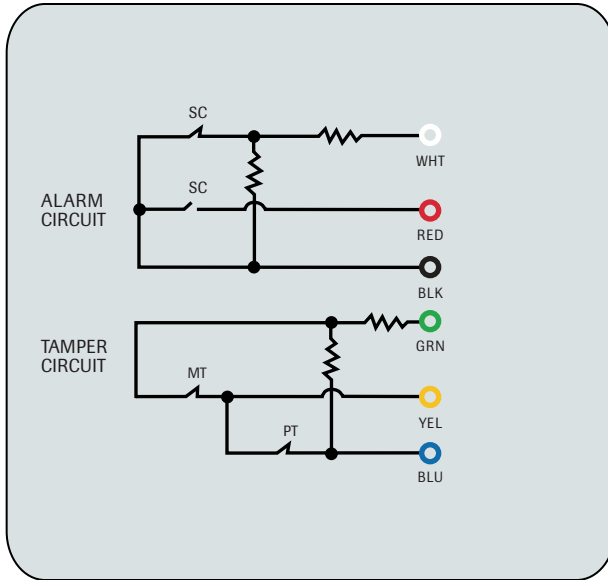

Figure 5



## Alarm and Tamper Circuits Specifications

Model L2S-XXX



**Max Current:**  
0.25 A Resistive

**Max Voltage:**  
30 VDC

**Max Power:**  
.25 W Resistive  
Suitable for outdoor use.

The MAGNASPHERE HSS Level 2 series is intended to be connected to a UL Listed compatible control panel for US applications and a ULC Listed compatible control panel for Canadian applications.

Model L2D-XXX

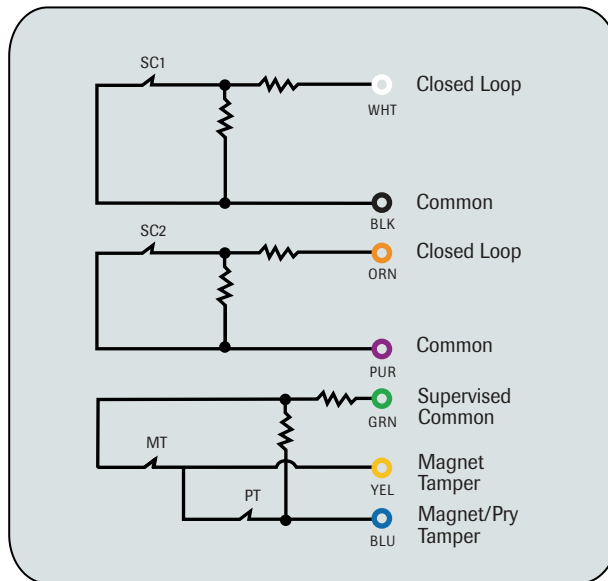

**Patents:**  
#5673021, #6603378  
& Patents Pending

## How the HSS Magnet / Removal Tamper Circuit Works

### **The MAGNASPHERE HSS Incorporates the Most Secure Anti-Tamper Feature of Any Device Available.**

In addition to the sensor inside that will detect the presence of a stronger defeat magnet placed on any surface of the HSS, the removal tamper circuit will alarm BEFORE the HSS can be removed.

You will notice that the mounting hole on the upper right face of the HSS sensor is larger than the other mounting holes and slightly offset towards the center of the sensor. A tamper-proof MAGNASPHERE switch is positioned inside the unit facing the bore of this mounting hole.

Whether you use the four mounting holes on the face of the sensor (in-swinging doors), or the two mounting holes on the bottom of the sensor (out-swinging doors), the upper right mounting hole with the removal tamper switch will be used.

Once the unit has been mounted, the removal tamper magnet (included) is inserted into this mounting hole. It will be attracted to the mounting screw and will activate the removal tamper switch. The mounting hole cover cap (included) is then inserted and locked into position.

In order to access that mounting screw to remove the sensor, the locking cap must be pried out, and a steel rod or magnet inserted into the hole to extract the tamper magnet. Removal of the tamper magnet will cause the removal tamper switch to alarm.

The HSS also includes anti-rotation pins that will prevent an intruder from removing the non-removal tamper mounting screws and twisting the HSS into a position where another door actuating magnet could be placed, simulating a secure position.